

CSI350 Intelligent addressable spur isolator unit



An extensive range of interfaces are available to support the Eaton range of control panels, providing solutions for most design requirements.

The spur isolator unit (CSI350) enables a spur of intelligent addressable devices to be connected to a main analogue loop, the device is designed to simplify installation of remote parts of buildings or for simple system extensions.

Features and benefits

- Integral short circuit isolator
- Allows a spur of intelligent addressable devices to be connected to the main loop
- Automatically controls addressing sequence
- Quick and simple to install
- No hard addressing required (Plug and play)
- Easy to expand a system using existing wiring
- Reduced installation cost
- Takes no address

Specifier's guide

2.5 Standard interfaces

Technical specification

Code	CSI350
Description	Spur isolator unit
Standards	EN54 Pt17 2005
Specification	
Quiescent current	170µA
Environmental	
Operating temperature	-10°C to +60°C
Humidity (non condensing)	0 to 95% RH
Physical	
Construction	PC/ABS
Dimensions (H x W x D)	88mm x 147mm x 60mm
Weight	0.23kg
Ingress protection	IP40
Compatibility	
Suitable for use with	Eaton intelligent addressable fire systems

Installation

1. Please refer to local installation standards for details of the maximum allowable area to be covered by a single zone.
2. Spur isolator unit is fixed to a deep double gang back box (supplied).
3. All connections are via heavy duty terminals.
4. Cable entry can be top, bottom, side or rear.
5. Can be surface or semi recessed mounted.

Dimensions

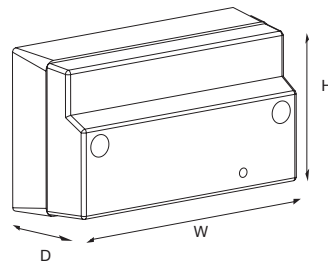

H (mm)	W (mm)	D (mm)
88	147	60

Standard connections

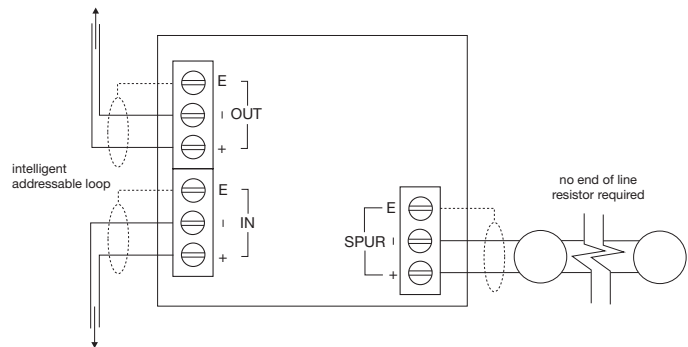

NOTES:

1. Earth (Screen) cable must be connected to its adjacent earth terminal.
2. Maximum spur length - see BS5839 Pt:1 20013 for zone coverage.
3. Unit can only be used with its respective Eaton fire systems compatible sensors and bases.

Catalogue numbers

Description	Code
Spur isolator unit	CSI350